

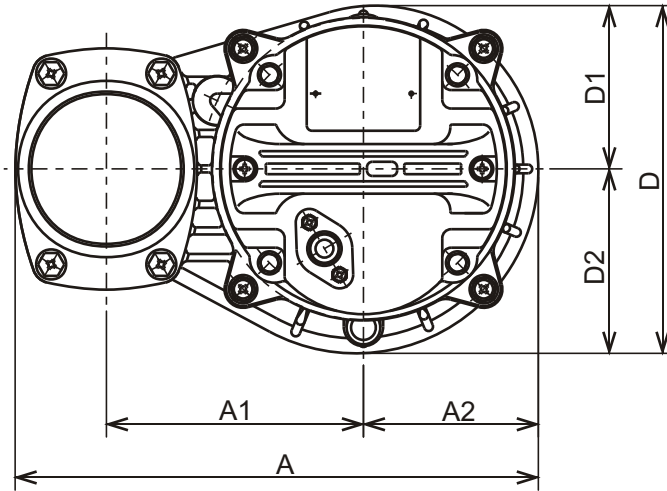

VANCS - SERIES - PSF
(FRP) EFFLUENT PUMPS

DIMENSIONS



80PSF21.5-62

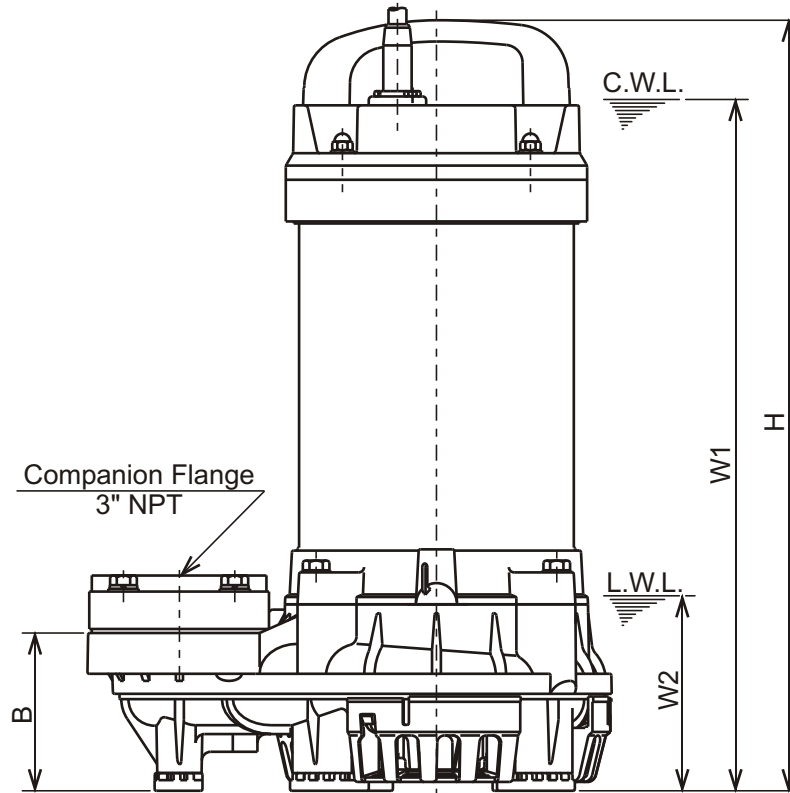

C.W.L. : Continuous running Water Level
L.W.L. : Lowest running Water Level

DIMENSIONS:USCS (In ch)

Model	HP	NOM. SIZE	Pump & Motor								C.W.L. W1	L.W.L. W2	Wt. (lbs.)
			A	A1	A2	B	D	D1	D2	H			
80PSF21.5-62	2	3"	11 5/8	5 11/16	3 7/8	3 1/2	7 11/16	3 5/8	4 1/8	17 1/8	15 3/8	4 3/8	35.2

DIMENSIONS:METRIC (mm)

Model	kW	NOM. SIZE	Pump & Motor								C.W.L. W1	L.W.L. W2	Wt. (kg)
			A	A1	A2	B	D	D1	D2	H			
80PSF21.5-62	1.5	80	295	145	99	89	196	92	104	435	390	110	16.0



VANCS-SERIES - PSF
(FRP) EFFLUENT PUMPS

DIMENSIONS

TOK80PSF21.5
(Slide Rail System
TOK2-65)

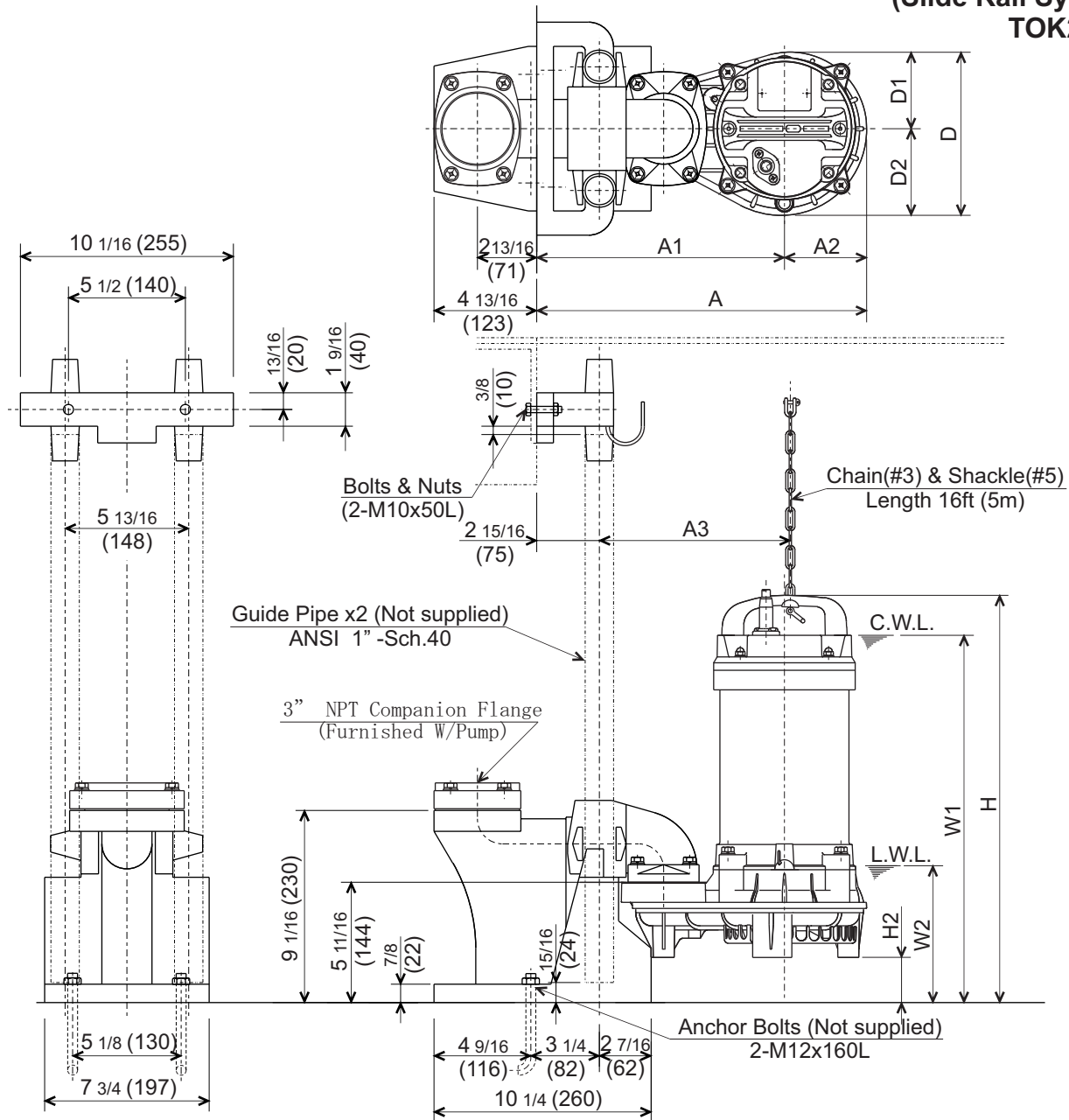

C.W.L. : Continuous running Water Level
L.W.L. : Lowest running Water Level

DIMENSIONS:USCS (Inch)

Model	HP	NOM. SIZE	Pump & Motor									C.W.L. W1	L.W.L. W2	Wt. (lbs.)
			A	A1	A2	A3	D	D1	D2	H	H2			
TOK80PSF21.5	2	3"	15 9/16	11 11/16	3 7/8	9 1/16	7 11/16	3 5/8	4 1/8	19 1/4	2 1/8	17 3/8	6 1/2	34.8

DIMENSIONS:METRIC (mm)

Model	kW	NOM. SIZE	Pump & Motor									C.W.L. W1	L.W.L. W2	Wt. (kg)
			A	A1	A2	A3	D	D1	D2	H	H2			
TOK80PSF21.5	1.5	80	396	297	99	231	196	92	104	489	54	441	164	15.8



VANCS - SERIES - PSF (FRP) EFFLUENT PUMPS

PERFORMANCE CURVE

MODEL	BORE	HP	KW	RPM	SOLIDS DIA	LIQUID	SG.	VISCOSITY	TEMP.
80PSF(A/W)21.5-62	3"/80mm	2	1.5	3455	0.512"/13mm	Water	1.0	1.123 CST	60°F
PUMP TYPE	PHASE	VOLTAGE		AMPERAGE		HZ	STARTING METHOD		INS. CLASS
Effluent Pump	3	208 - 220 / 440		6.9 - 6.6 / 3.6		60	Direct On Line		E
CURVE No.	DATE	PHASE	VOLTAGE	AMPERAGE	HZ	STARTING METHOD		INS. CLASS	
-	-	-	-	-	-	-		-	

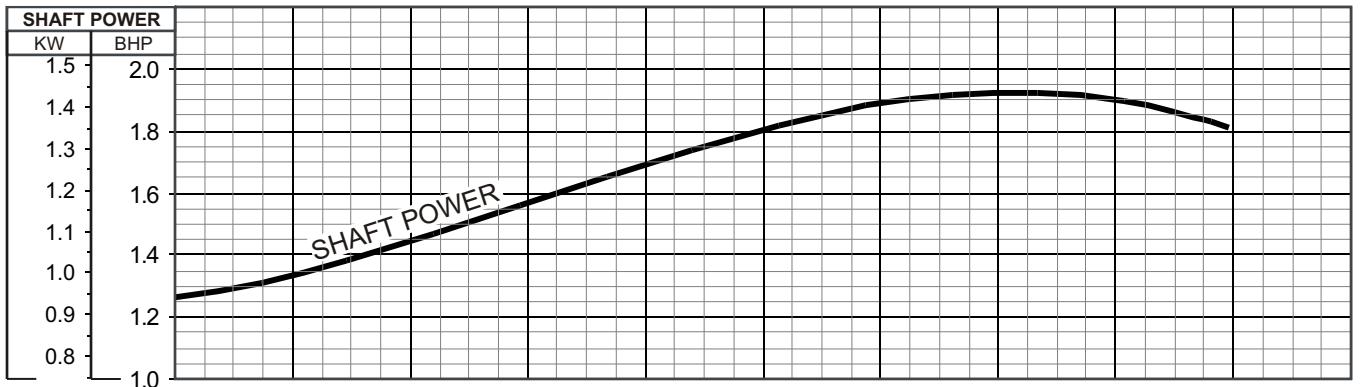
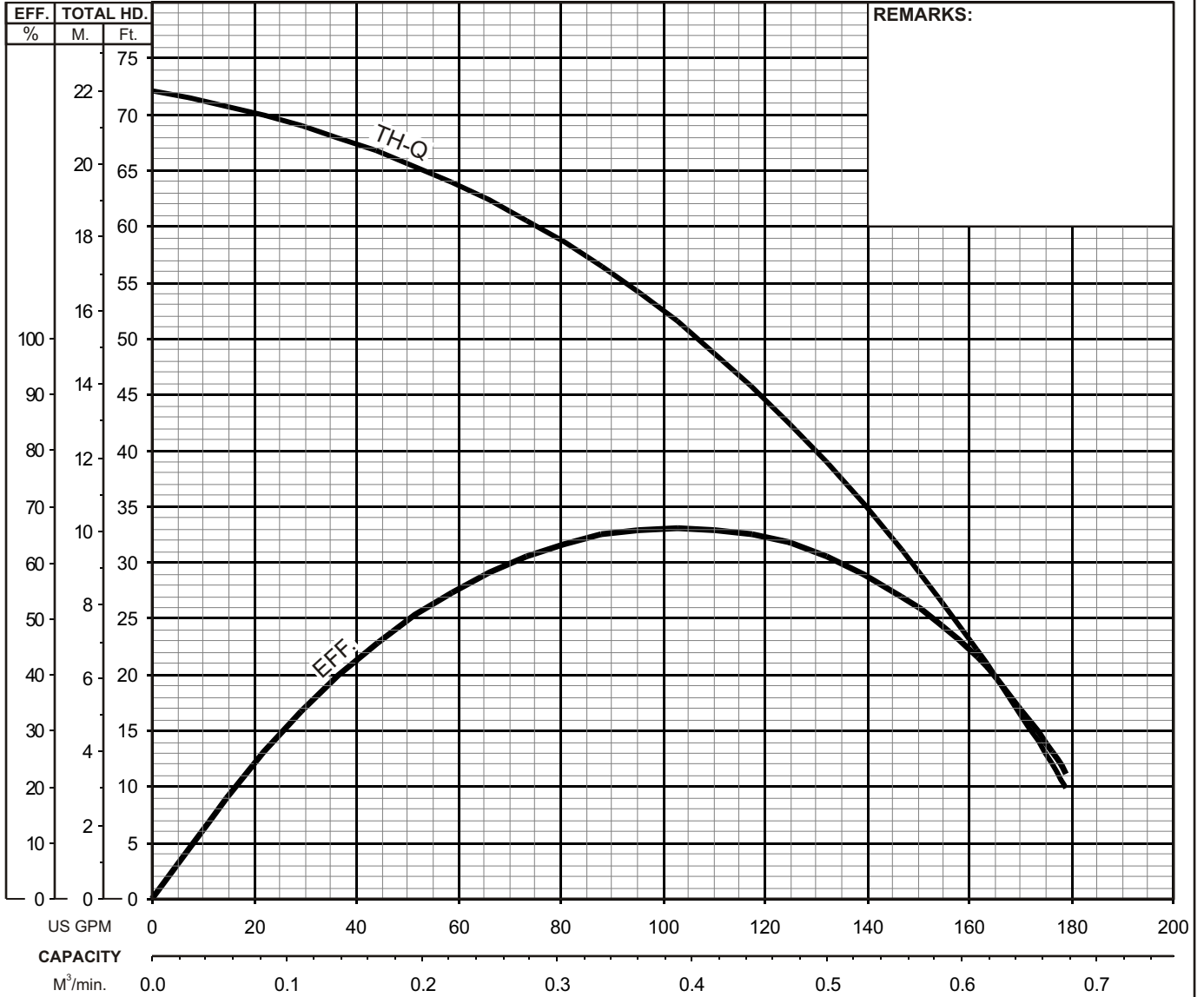



VANCS - SERIES - PSF
(FRP) EFFLUENT PUMPS

SECTIONAL VIEW

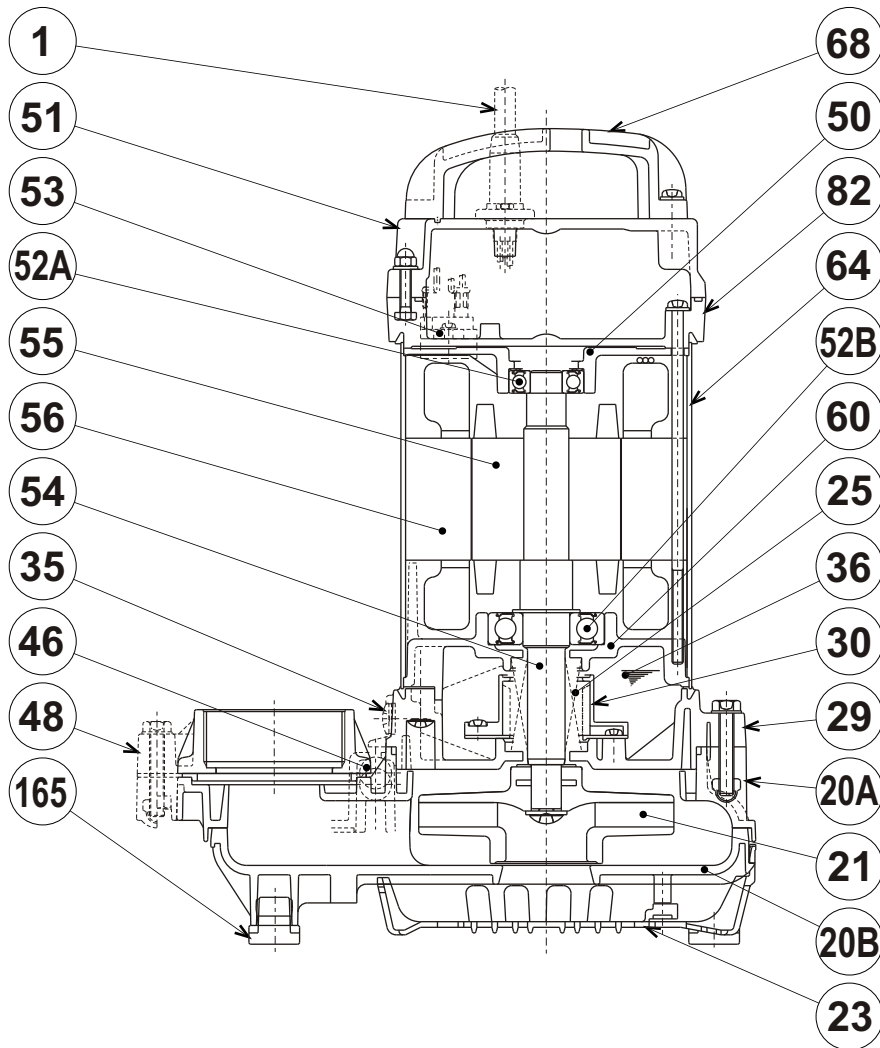

80PSF21.5-62

PART#	DESCRIPTION	MAIN MATERIAL / NOTE	RELATED ASTM, AISI CODE	RELATED EN CODE	QTY
1	Power Cable	PVC Sheath AWG16/4-32ft			1
20A	Upper Pump Casing	PA+ABS Plastic w/GF30			1
20B	Lower Pump Casing	PA+ABS Plastic w/GF30			1
21	Impeller	PPO Plastic w/GF20			1
23	Suction Strainer	ABS Plastic			1
25	Mechanical Seal	Silicon Carbide / H-20A			1
29	Oil Casing	PPS Plastic w/(GF+MD)50			1
30	Oil Lifter	PBT Plastic W/(GF+MD)40			1
35	Oil Plug	Stainless Steel	S 30400	1.4301	1
36	Lubricant	White Mineral Oil ISO VG32			
46	Air Valve	Glass Ball			1
48	Companion Flange	PVC / NPT 3"			1
50	Motor Bracket	Aluminum Alloy Die Casting	B85 383.0	EN 1706 AC-46100	1
51	Motor Head Cover	PPS Plastic w/GF40			1
52A	Upper Bearing	#6203ZZC3			1
52B	Lower Bearing	#6305ZZC3			1
53	Motor Protector				1
54	Shaft	Stainless Steel	S 30400	1.4301	1
55	Rotor				1
56	Stator				1
60	Bearing Housing	Aluminum Alloy Die Casting	B85 383.0	EN 1706 AC-46100	1
64	Motor Housing	Stainless Steel	S 30400	1.4301	1
68	Handle	ABS Plastic			1
82	Motor Head Cover Spacer	PPS Plastic w/GF40			1
165	Rubber Cushion	Nitrile Butadiene Rubber			5

PARTS LIST		VANCS SERIES PUMPS			10/10/2017	
ITEM	PART No.	DESCRIPTION	QTY	SIZE	MATERIAL	NOTES
1	001-803-20	Cabtyre Cable Set (32') 60Hz (USA)	1	VCT4Cx1.25mm2	LBT	
2	143-000-33	Hex. Tapping Screw	2	M5x20	SUS304	
3	003-190-10	Gland	1		SUS316	
4	143-198-15	Pan Tapping Screw	2	M6x30	SUS304	
5	142-126-19	Plain Washer	2	M6	SUS304	
6	068-278-14	Handle	1	15-PUT	Resin	
7	051-262-13	Motor Head Cover	1		Resin	
8	141-029-18	Hex. Cap Nut	4	M6	SUS304	
9	142-126-19	Plain Washer	4	M6	SUS304	
10	143-138-17	Truss Tapping Screw	2	M4x12	SWCH	
11	053-510-15	Motor Protector 208/220V-60Hz (USA)	1	KA313-GBVL102J	(T)	
	053-001-65	Motor Protector 440V-60Hz(USA)	1	KA313-GQVL104J	(T)	
12	121-569-13	Packing	1	15-PUT/PNT/PSHT	NBR	*
13	143-199-16	Pan Screw	4	M6x190	SWRM	
14	142-113-26	Plain Washer	4	M6(D=11.5)	SPC	
15	082-106-14	Head Cover Spacer	1		Resin	
16	121-570-17	Packing	1	d152xd161x2.1t	NBR	*
17	143-085-34	Pan Screw (w/Spring Washer)	1	M4x6	C3604	
18	009-187-12	Earth Terminal	1Set	1.25mm2x150L		
19	050-464-14	Motor Bracket	1		ADC	
20	056-B78-16	Stator(w/M.Frame) 208/220V-60Hz (USA)	1Set			
		Stator(w/M.Frame) 440V-60Hz(USA)	1Set			
21	142-435-14	Wave Washer	1	BBY060311A0	SUP	
22	052-102-17	Bearing	1	6203ZZC3		
23	055-830-10	Rotor	1Set	w/Bearing		
24	061-161-12	Bearing Collar	1	d25.1xd36x1.6t	SPC	
25	052-108-13	Bearing	1	6305ZZC3		
26	060-000-91	Bearing Housing	1		ADC	
27	025-252-19	Mechanical Seal	1	H-20A	SIC+CCBN	
28	143-070-23	Pan Screw	2	M5x6	SWRM	
29	030-144-13	Oil Lifter	1	H-20(A)(T)	Resin	
30	143-193-10	Pan Tapping Screw	2	M5x12	SWRM	
31	030-153-15	Seal Stopper	1	H-20(A)	SPCC	
32	121-567-11	Packing	1	15-PU/P(N)(A)(W)T/PSHT	NBR	*
33	035-127-15	Oil Plug	1	M10x15	SUS304	
34	121-246-11	Packing	1	d10.3xd16x2t	PE	*
35	029-380-19	Oil Casing	1	15-PUT	Resin	
36	140-000-09	Hex. Bolt	4	M8x45	SUS304	

* Indicates items included in set

PARTS LIST		VANCS SERIES PUMPS				10/10/2017
ITEM	PART No.	DESCRIPTION	QTY	SIZE	MATERIAL	NOTES
37	143-194-11	Truss Screw (w/Polyethylene Washer)	6	M6x30	SUS304	
38	142-428-14	Conical Spring Washer	1	d16.3xd31.5x1.2t	SUS304	
39	021-008-23	Impeller (60Hz)	1	80PSF21.5-62	Resin	
	021-P53-19	Impeller (50Hz) OPTION	1	80PSF21.5-52	Resin	50Hz OPTION
40	143-195-12	Truss Screw (w/Plain Washer)	1	M8x18	SUS304	
41	122-276-13	O-Ring	1	160xd3.1	NBR	*
42	140-000-09	Hex.Bolt	4	M8x45	SUS304	
43	048-268-19NPT	Screwed Flange	1	NPT-3(1.5kW)	Resin	also 048-000-75
44	121-568-12	Packing	1	d84xd98x5t	NBR	*
45	020-002-22	Pump Casing	1	50PN/PSF21.5-52/62	Resin	
46	141-121-11	Hex.Nut	2	M8(B=12)	SUS304	
47	165-000-07	Rubber Feet	5	PU/PN/PSF21.5-52/62	NBR	
48	023-000-96	Strainer	1	50PN21.5-52/62	Resin	
49	143-000-10	Truss Tapping Screw	4	M4x18	SUS304	
	173-563-18	Packing O-Ring Set	1Set	(Marked by *)		
12	121-569-13	Packing (Head Cover/Head Cover Spacer)	1	15-PUT/PNT/PSHT	NBR	*
16	121-570-17	Packing (Head Cover Spacer/M.Frame)	1	d152xd161x2.1t	NBR	*
32	121-567-11	Packing (M.Frame/O.Casing)	1	15-PU/P(N)(A)(W)T/PSHT	NBR	*
34	121-246-11	Packing (Oil Plug)	1	d10.3xd16x2t	PE	*
41	122-276-13	O-Ring (O.Casing/P.Casing)	1	160xd3.1	NBR	*
44	121-568-12	Packing (Screwed Flange)	1	d84xd98x5t	NBR	*
		Lubricant		Liquid Paraffin VG32 500ml		

PARTS LIST		VANCS SERIES PUMPS		10/10/2017		
ITEM	PART No.	DESCRIPTION	QTY	SIZE	MATERIAL	NOTES

EXPLODED VIEW

80PSF21.5-62

